

THIS DRAWING AND ALL INFORMATION CONTAINED HEREIN IS THE PROPERTY OF WELDON TECHNOLOGIES, INC. AND MAY NOT BE COPIED, REPRODUCED, OR DIVULGED TO UNAUTHORIZED PERSONS WITHOUT THE EXPRESS WRITTEN CONSENT OF WELDON TECHNOLOGIES, INC. AS IT IS BEING PROVIDED SOLELY FOR THE CONVENIENCE OF THE USER AND SHALL BE RETURNED TO WELDON TECHNOLOGIES, INC. UPON REQUEST.

REVISIONS					
REV.	ECN	DESCRIPTION	DATE	BY	APVD
B	R0332	DOCUMENTATION RELEASE	5/16/02	TS	ST
Ⓒ	0362	INCORRECT PART NO'S FOR RIGHT AND LEFT ARROW LAMPS. ADDED HOLE PLUG NO.	5/24/02	TS	ST

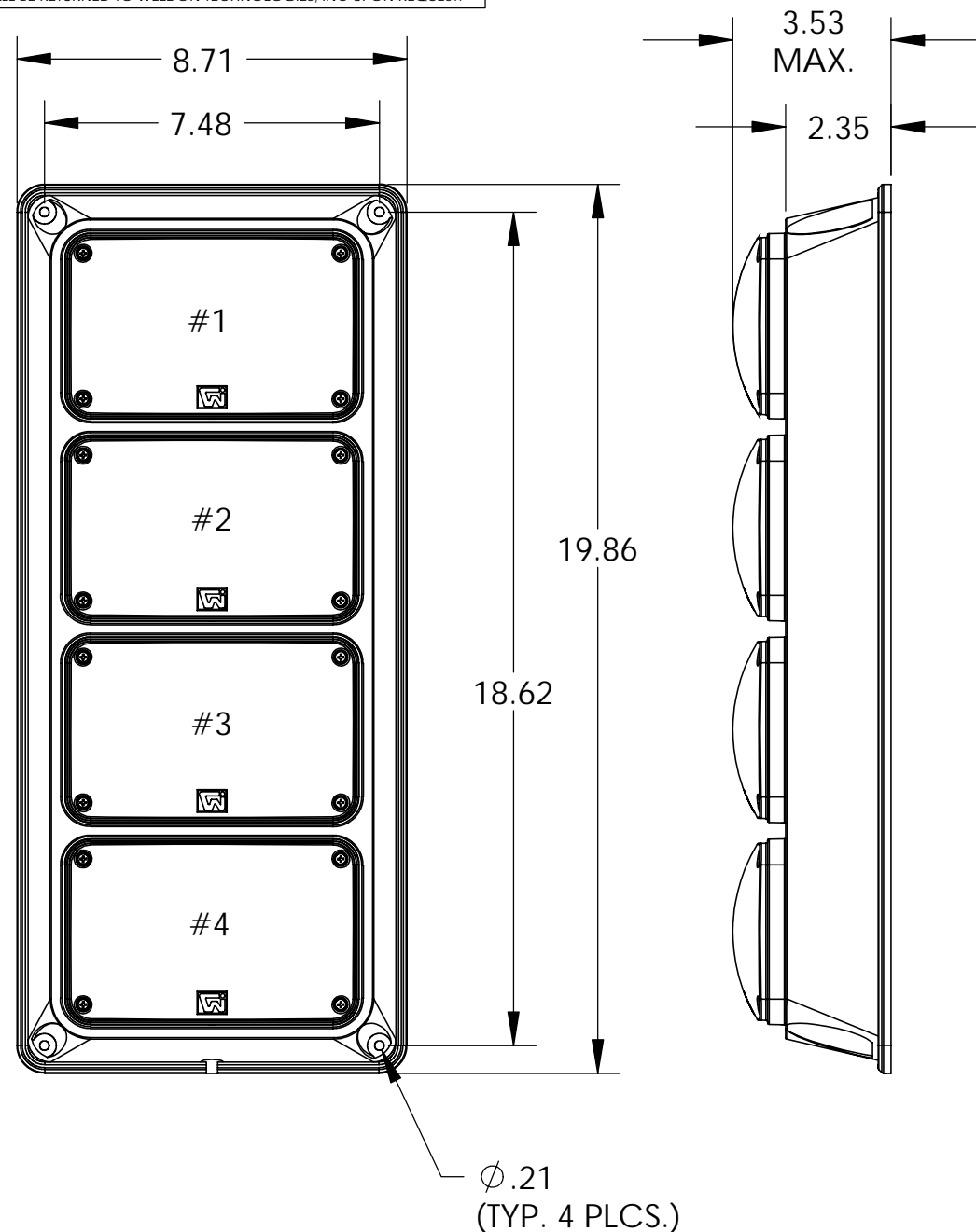

FUNCTION	WIRE COLOR	DEUTSCH POSITION	PACKARD POSITION	INCANDESCENT BULB TYPE	INCANDESCENT LAMP SUB-ASSM	LED LAMP SUB-ASSM
STOP	RED	1	A	1157	0C90-0351-10	0C90-1295-10
TAIL	BLACK	2	B			
LEFT TURN	GREEN	3	C	1156	0C90-0352-21	0C90-1295-21
RIGHT TURN	GREEN	3	C	1156	0C90-0352-22	0C90-1295-22
BACK UP	BLUE	4	D	1156	0C90-0350-33	0C90-1295-30
GROUND	WHITE	5	E	-	-	-

NOTE: CUSTOMER WIRING HARNESSES SHOULD BE TERMINATED AS FOLLOWS:

	DEUTSCH	PACKARD
CONNECTOR BODY	DT06-6S	12186400
TERMINAL	0462-201-16141 (16, 18, 20 AWG)	12048159 (1.0-0.8 CABLE RANGE)
LOCKING WEDGE	W6S	N/R
TPA (STRAIN RELIEF)	N/R	12084673
SEAL	N/R	12015323 (2.85-2.03 CABLE DIA.)
Ⓒ HOLE PLUG	0413-204-2005	N/R

TERMINALS AND SEALS ACCOMMODATING OTHER WIRE DIAMETERS ARE AVAILABLE FROM CONNECTOR SUPPLIER

MODEL NO.	LAMP POSITION			
	#1	#2	#3	#4
4694-0000-01	OPEN	STOP/TAIL	LEFT ARROW TURN Ⓒ	BACK UP
4694-0000-02	OPEN	STOP/TAIL	RIGHT ARROW TURN Ⓒ	BACK UP
4694-0171-18	LED RED, WARNING	LED STOP/TAIL	LED SEQUENTIAL L. TURN	BACK UP
4694-0171-19	LED RED, WARNING	LED STOP/TAIL	LED SEQUENTIAL R. TURN	BACK UP

UNLESS OTHERWISE SPECIFIED DIMENSIONS ARE IN INCHES TOLERANCES ARE: X.XXX - ±0.005 X.XX - ±0.020 X.X - ±0.050 ANGLES - ±0.5°	CAD GENERATED DRAWING, DO NOT MANUALLY UPDATE		WELDON TECHNOLOGIES, INC.	
	APPROVALS	DATE		
	MATERIAL	DRAWN TS 5/8/02	MECHANICAL OVERVIEW 4694 SERIES QUAD-CLUSTER	
	FINISH	CHECKED ST 5/15/02		
DO NOT SCALE DRAWING	PROJ. NO.	SIZE B	PART NO. C4694	REV. C
SCALE: 1:1		WELDON COMPUTER GRAPHICS SHEET 1 OF 1		