

THIS DRAWING AND ALL INFORMATION CONTAINED HEREIN IS THE PROPERTY OF WELDON TECHNOLOGIES, INC. AND MAY NOT BE COPIED, REPRODUCED, OR DEVIATED TO UNAUTHORIZED PERSONS WITHOUT THE EXPRESS WRITTEN CONSENT OF WELDON TECHNOLOGIES, INC. AS IT IS BEING PROVIDED SOLELY FOR THE CONVENIENCE OF THE USER AND SHALL BE RETURNED TO WELDON TECHNOLOGIES, INC. UPON REQUEST.

REV		ECN		DESCRIPTION		DATE	BY	APVD
A		R0547		RELEASE FOR REFERENCE		8/25/04	TB	ST

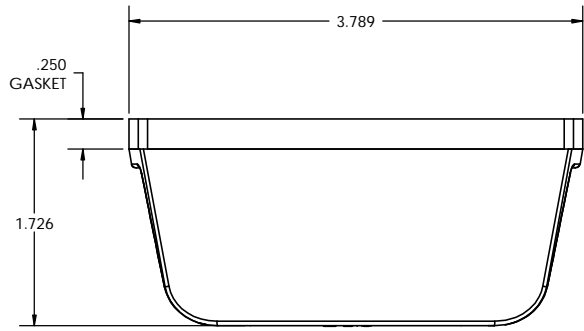

LED MARKER LAMP ASSEMBLY  
 WELDON PART NUMBER  
 RED: 5170-0100-10  
 AMBER: 5170-0100-20  
 (INCLUDES MOUNTING GASKET)

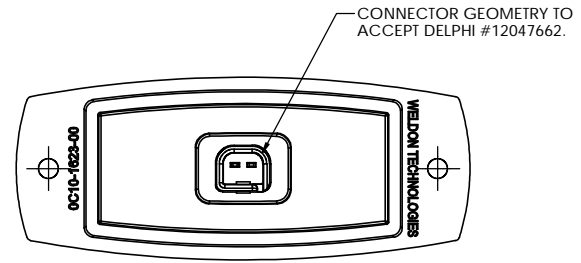
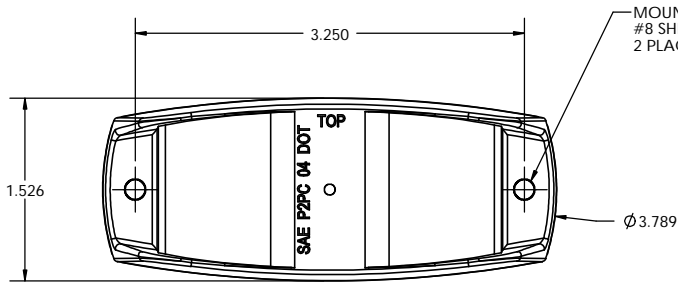
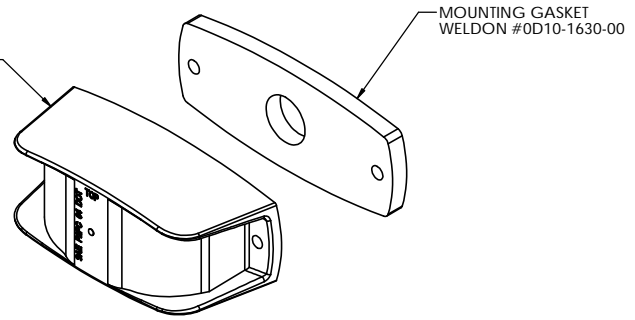

- NOTES:
- THIS LAMP ASSEMBLY MUST COMPLY WITH FMVSS 108 AND ANY SAE STANDARD REFERENCED THEREIN WITH RESPECT TO THE FOLLOWING:
    - COMBINATION CLEARANCE/SIDEMARKER LAMPS (270 DEGREE) PER SAE J592e JUL72
    - PLASTIC MATERIALS PER SAE J576 JUL91
    - COLOR PER SAE J578c FEB77
    - TEST METHODS PER SAE J575e AUG70
  - CARTON QUANTITY TO BE 50 PIECES.
  - LAMP TO ACCEPT DELPHI CONNECTOR #12047662 - METRI-PACK 150 SERIES.
  - OPERATING VOLTAGE RANGE: 10VDC - 16VDC

UNLESS OTHERWISE SPECIFIED DIMENSIONS ARE IN INCHES TOLERANCES ARE:	CAD GENERATED DRAWING. DO NOT MANUALLY UPDATE		WELDON TECHNOLOGIES, INC.	
	APPROVALS	DATE	L.E.D. CLEARANCE/MARKER ASSY 270 DEGREE ILLUMINATION	
MATERIAL	DRAWN	7/30/04	REV.	
	CHECKED	8/9/04	C5170-0100-00	
FINISH	QUAL ENG		SCALE: 1:1	
	MFG ENG		WELDON COMPUTER GRAPHICS SHEET 1 OF 1	
DO NOT SCALE DRAWING	PROJ. NO.	00155		