

THIS DRAWING AND ALL INFORMATION CONTAINED HEREIN IS THE PROPERTY OF WELDON TECHNOLOGIES, INC. AND MAY NOT BE COPIED, REPRODUCED, OR DIVULGED TO UNAUTHORIZED PERSONS WITHOUT THE EXPRESS WRITTEN CONSENT OF WELDON TECHNOLOGIES, INC. AS IT IS BEING PROVIDED SOLELY FOR THE CONVENIENCE OF THE USER AND SHALL BE RETURNED TO WELDON TECHNOLOGIES, INC UPON REQUEST.

REVISIONS				
REV.	ECN	DESCRIPTION	DATE	BY APVD
A	R0521	RELEASE FOR REFERENCE	4/23/04	ST ST

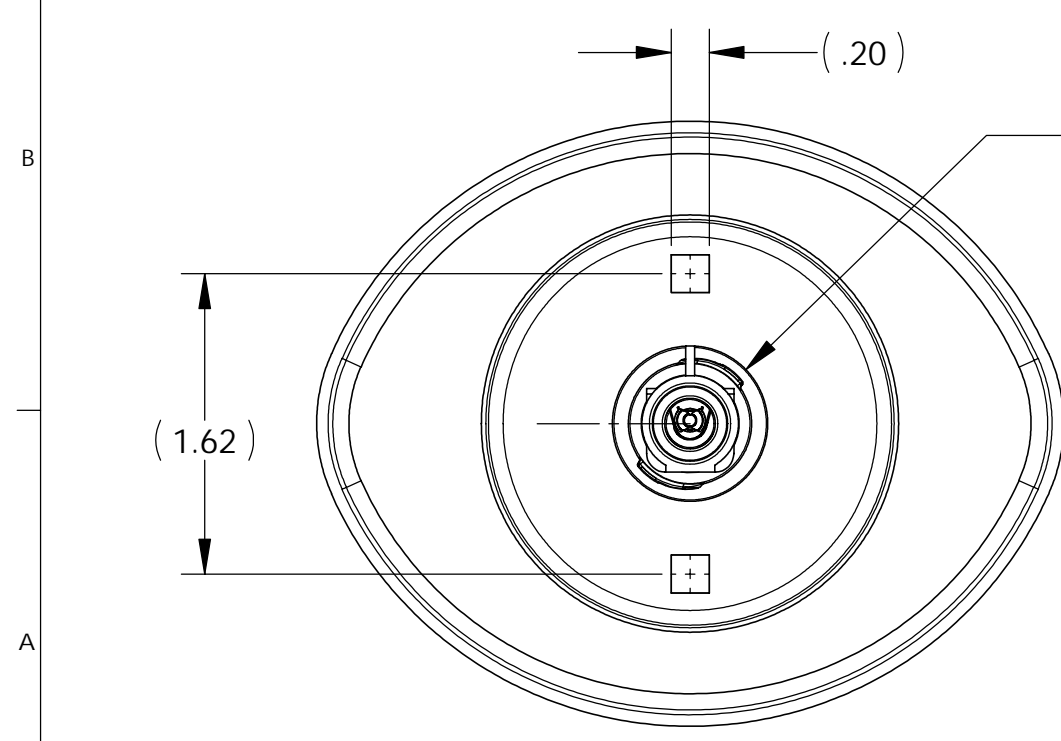
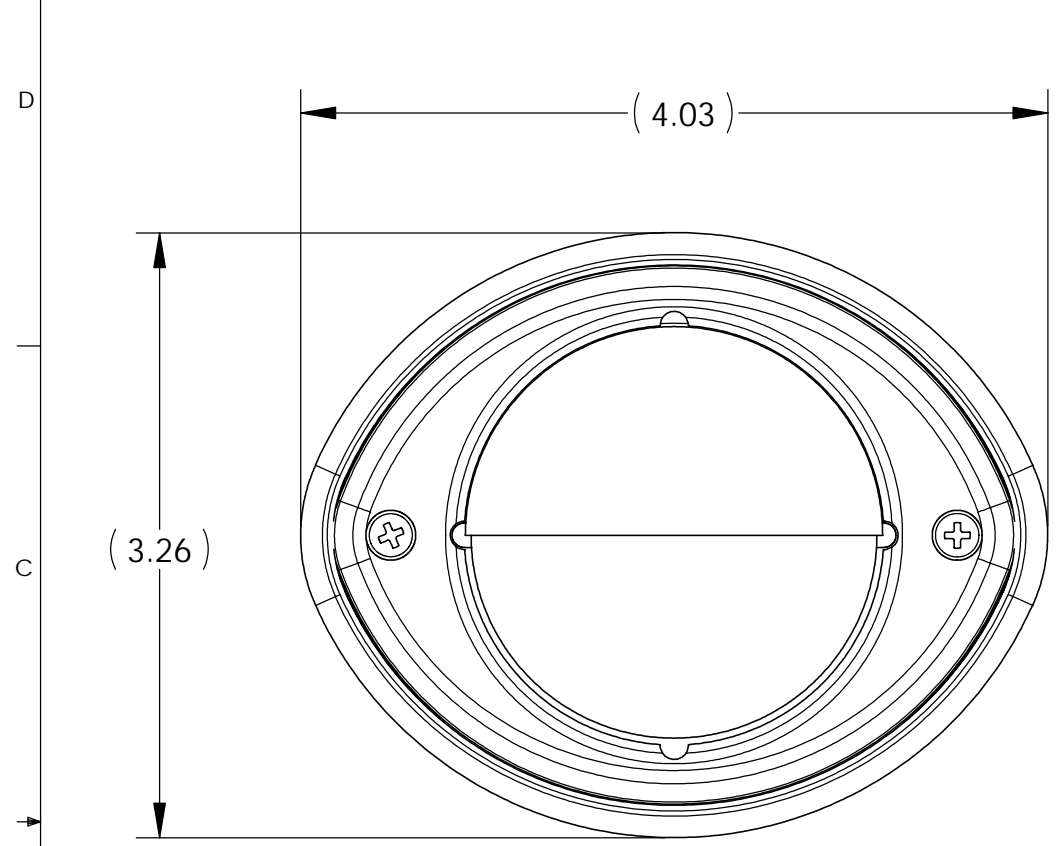

BACK VIEW

Ø .87 MIN. CLEARANCE HOLE

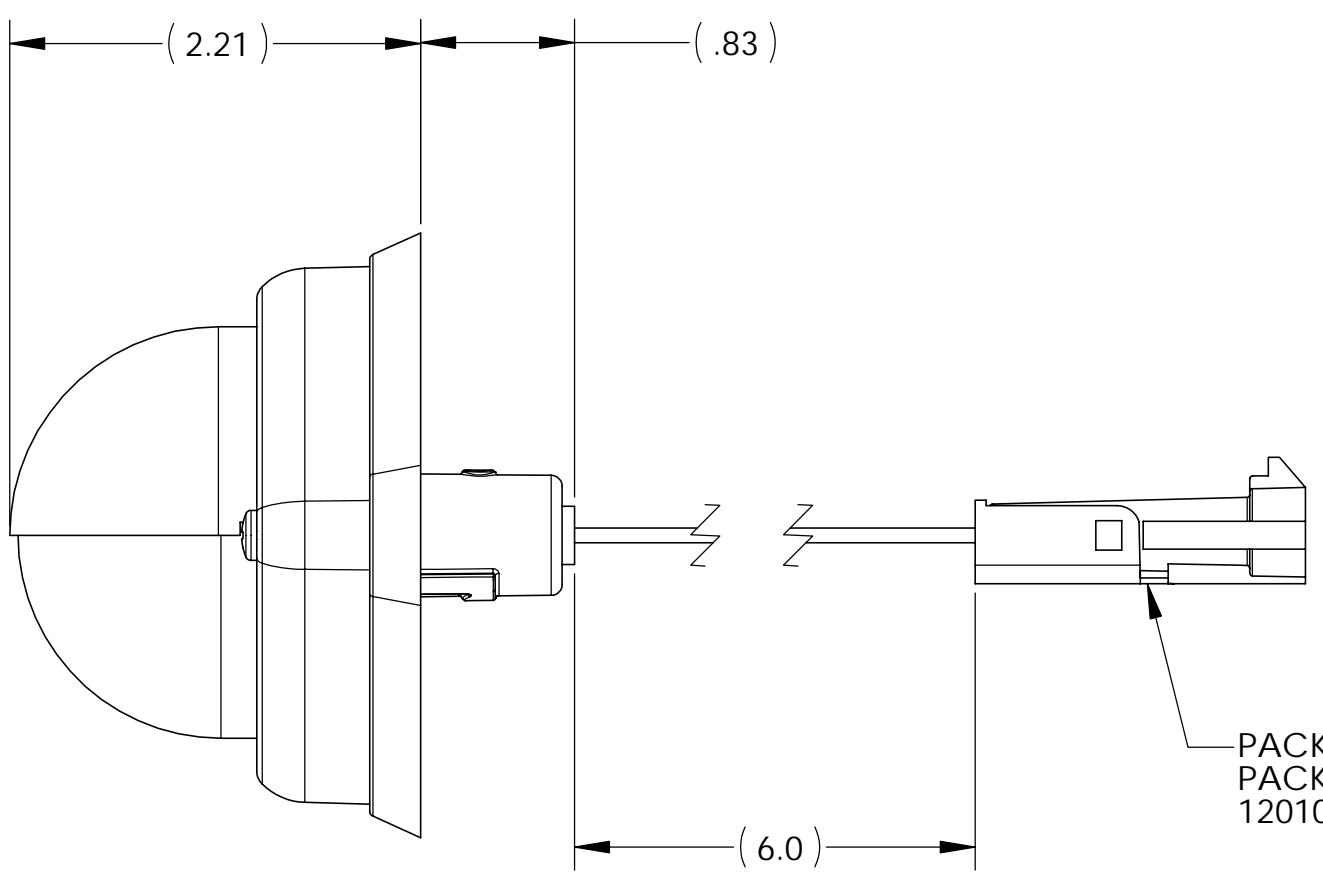

MATERIALS:
 HOUSING AND SOCKET - STEEL, ZINC PLATE WITH CHROMATE CONVERSION COATING
 SHIELD AND BEZEL - POLISHED STAINLESS STEEL
 LENS - GLASS, CLEAR
 BEZEL SCREWS - #8-32, STAINLESS STEEL, PASSIVATED
 LENS GASKET - SILICON RUBBER, WHITE
 MOUNTING PAD - BLACK, PVC
 BULB - #1141, 21CP, S-8, SINGLE CONTACT

NOTE:
 DIMENSIONS IN () ARE FOR REFERENCE ONLY.

UNLESS OTHERWISE SPECIFIED DIMENSIONS ARE IN INCHES TOLERANCES ARE: X.XXX - ±0.005 X.XX - ±0.020 X.X - ±0.050 ANGLES - ±0.5°	CAD GENERATED DRAWING. DO NOT MANUALLY UPDATE		WELDON TECHNOLOGIES, INC.	
	APPROVALS	DATE	CUSTOMER DRAWING: STEPWELL LAMP CLEAR, 21 CP, SINGLE WIRE W/ PACKARD WEATHER-PACK	
DRAWN	ST 4/23/04	SIZE		
MATERIAL	CHECKED	ST 4/23/04	B	C9186-8564-31
FINISH	DO NOT SCALE DRAWING		PROJ. NO.	REV. A
SCALE: 1:1		WELDON COMPUTER GRAPHICS SHEET 1 OF 1		