



## 1020-9000 Series LED Warning Light

The 1020-9000 Series is a revolutionary, eco-friendly LED Warning Lamp which combines advanced electronics plus a conventional idea of serviceable parts. Designed for long-term service, this warning lamp allows the lens to be changed or to upgrade LED's; eliminating the need to replace the entire light should a part be damaged thus reducing landfill waste. Further, the 1020-9000 series was designed with Weldon's commitment to global environmental awareness by reducing hazardous chemicals such as lead in the manufacturing process.



Patented V-LED design allows replacement of LEDs

Weldon's LED Warning Lamps utilize worldwide patented V-LED Light Emitting Diodes. The V-LED's threaded mounted design provides the most efficient thermal management in the industry, allowing extraordinary brightness and warning power with the lowest current draw. As an invaluable added benefit, the V-LED diodes are field upgradable as future LED technologies emerge.

By choosing Weldon's 1020-9000 Series LED Warning Lamps, you are making the conscious decision to lessen the environmental impact from your School Bus Fleet, without sacrificing even the slightest ability to protect your students.

There is no other LED Warning Lamp available today that offers upgradeable LED technology, field serviceability of primary components, or lower life-cycle cost.

- Cover lens is easily replaced with four screws. Advanced design for maximum optical performance.
- Exclusive patented V-LED technology for superior thermal efficiency, excellent brightness and energy efficient electronics.
- Utilizes only 8 high-power LED's for optimal output intensity; fully illuminating the entire lens. LED's are field upgradable.
- Standard lead wires allow flexibility to add the connector of choice.
- Strobing and standard flash in one lamp.
- Instant on for improved visibility and safety.
- No switch mode regulation – eliminates radio interference.
- Exceeds SAE J887 requirements - DOT (FMVSS108) compliant
- 5 Year warranty



1020-9000-10



1020-9000-20



**WELDON**  
A DIVISION OF AKRON BRASS

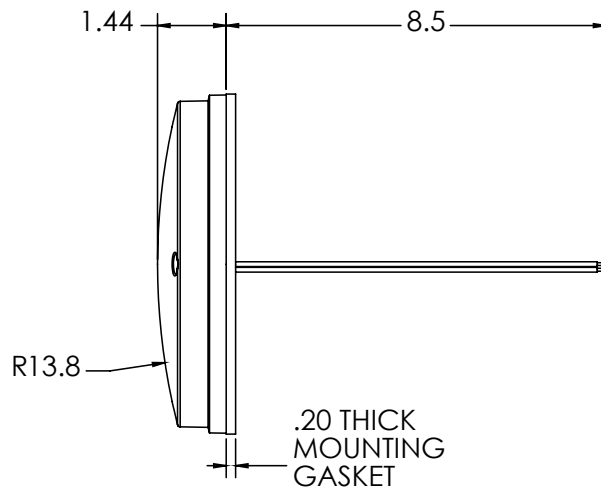
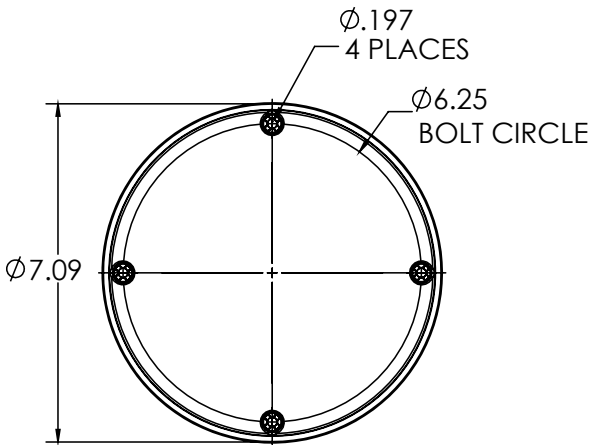
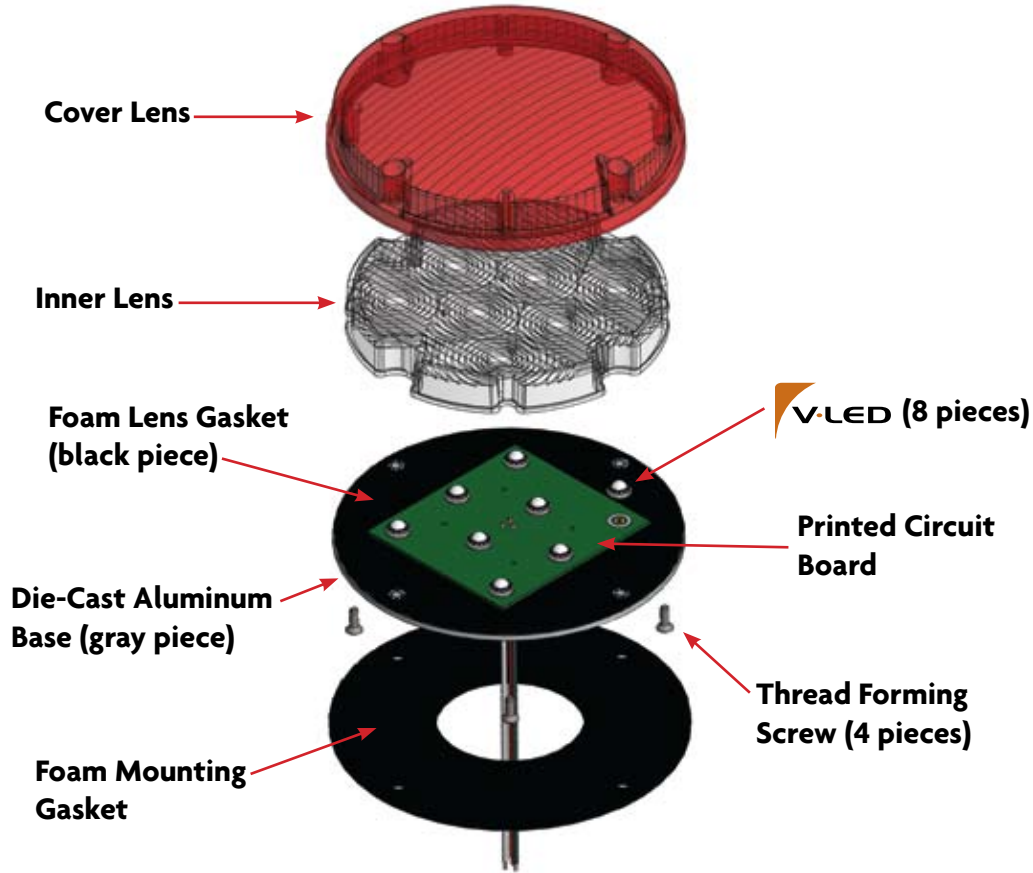

www.weldoninc.com



**WELDON**  
A DIVISION OF AKRON BRASS

ISO 9001: 2000 Registered Company  
In U.S./International  
Weldon, a division of  
Akron Brass

PH: 614.529.7230  
PH: 800.989.2718  
FAX: 614.527.3547

**PH: 800.989.2718 | Fax: 614.527.3547 | www.weldoninc.com**

© Copyright 2010 Akron Brass Company. All rights reserved. No portion of this can be reproduced without the express written consent of the Akron Brass Company. (07/10)

3565 Paragon Drive  
Columbus, OH 43228